

LONG PULSE MARX BANK MODULATOR FOR THE ILC

J. Casey, R. Ciprian, I. Roth, M. Kempkes, M. P.J. Gaudreau, F. Arntz

Diversified Technologies, Inc., 35 Wiggins Avenue, Bedford, MA 01730 USA

Abstract

Diversified Technologies, Inc. (DTI) has developed high power, solid-state Marx Bank modulators for a range of accelerators and colliders. We estimate the Marx topology can deliver equivalent performance to conventional designs, while reducing system costs by 25-50%.

In this paper DTI will describe the application of Marx based technology to a long-pulse (140 kV, 160 A, 1.5 ms) modulator design focused on the International Linear Collider. The primary engineering challenge is minimizing the overall size and cost of the storage capacitors in the modulator. Unique choices in components and controls are needed, including the use of electrolytic capacitors. This paper will review recent progress in the development and testing of this long pulse Marx modulator built under a U.S. Department of Energy Phase II SBIR grant.

INTRODUCTION

In the last decade, advances in solid-state switches have enabled a new class of Marx modulators that use “opening switch” technology as basic building blocks. The technology brings three key benefits to modulator design. First, the switches may open under fault conditions with sub-microsecond response, eliminating the full energy discharge into a load arc, and the need for arc protection crowbars. Second, the capacitors may be sized for an arbitrarily small droop during the pulse duration, eliminating the need for pulse forming circuitry. Third, the triggering of the individual stages may be staggered, with the non-triggered stages bypassed via a diode, allowing programmable waveform synthesis within a single high voltage pulse.

BASICS OF MARX MODULATORS

The basic Marx cell is composed of an energy storage capacitor and a pulse switch, with a bypass diode spanning them both (Figure 1). When the pulse switch is closed, the capacitor is added in series to the circuit, erecting the high voltage pulse. If the switch remains open, but other cells are closed (and pulse current is flowing), the bypass diode is pulled into conduction and the cell contributes nothing to the series voltage.

This choice – to fire or not to fire the pulse switch – is key to synthesizing the desired waveform during the pulse. The usual application is to compensate for capacitor droop by firing additional cells as the voltage falls. We can also use such waveform synthesis to actively compensate for transient effects, such as leading edge ringing due to parasitic capacitance.

Between pulses, the energy storage capacitors must be recharged. At very low repetition rates, this charge can be dribbled in with high impedance resistance or high inductance daisy-chain wiring, which carries little current during the erection of the pulse. For short pulse durations, a common-mode choke topology can be used, with differential leads to recharge the capacitors at low impedance, while providing common-mode impedance

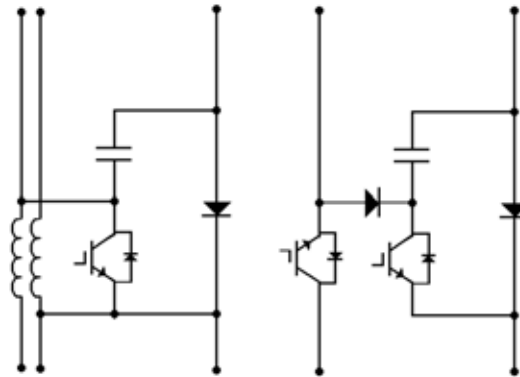

Figure 1. (left) A single Marx cell, recharged via common mode choke, is suitable for short pulses. (right) Long pulses require prohibitively large choke cores, thus recharge is better served via a second switch.

during the pulse. This technique becomes impractical for long pulse durations, however, because the choke core would become prohibitively large to avoid saturation. Instead, for long pulses, a second string of high voltage switches is used to supply a charging chain. These switches are fired with gating complementary to the pulse switches (Figure 1).

DTI has more than a decade of experience building series arrays of IGBTs that act as single switching elements, and are sufficiently robust to use as hard switches in systems over 100 kV. These arrays are ideal for sizing the voltage rating of individual cells in a Marx modulator to optimize the overall system performance. The use of such series arrays can yield a further advantage. Since IGBTs generally fail short, a properly sized system can lose a single IGBT and continue to operate at full specification. To achieve this level of redundancy, a reasonable number (at least five or six) of series IGBTs comprise each cell. Failure of the modulator thus requires multiple failures within a single cell, and failure of multiple cells.

LONG PULSE (ILC) MARX MODULATOR

The ILC modulator has specifications of 140 kV, 160 A, 1.5 ms, and 5 Hz. ILC modulator engineering is

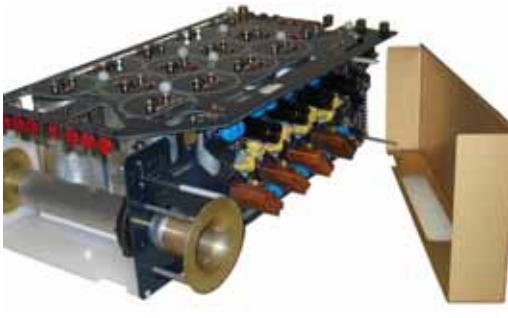

Figure 2. Photo of a long pulse “core” module shows the 8.2 kJ electrolytic capacitor bank and the two four-stage 7kV IGBT switch arrays.

completely dominated by the long pulse, and the very large delivered energy per pulse.

A simple hard switch – or a Marx modulator with simultaneous firing of all cells – would need an energy storage capacitor bank of ~ 1.5 MJ to maintain the specified 1% flattop. This is prohibitive because of physical size limitations and cost. Our preference for a Marx topology is motivated primarily by its capability for waveform synthesis, which allows us to reduce the capacitor bank by a factor of nearly 10, without sacrificing the 1% flattop specification.

The key to achieving this without unwieldy high charging currents is to use a dual-size cell approach (Figure 3). We chose a 6-7 kV cell size for the core cells – each with 8.2 kJ of series electrolytic capacitors and a six stage IGBT switch for pulsing. A second identical

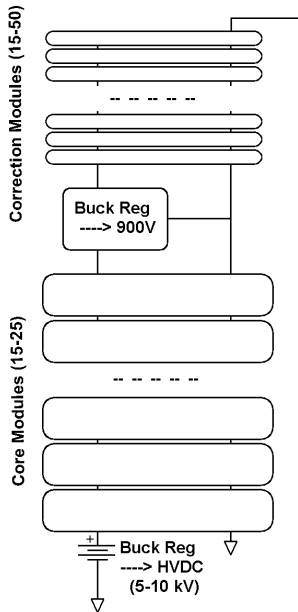

Figure 3. The topology of the ILC Marx modulator includes a dual voltage scheme to efficiently pulse to high voltage, yet regulate the flat top pulse with small steps.



Figure 4. The ILC Modulator is a compact unit, for immersion in a 7' x 5.5' oil tank, with controls on top and coax cable pulse output.

switch is used for the charging circuit, eliminating the need for a common mode choke. All of the core modules are fired simultaneously to erect the initial pulse voltage, with high reliability ensured by the $N+1$ redundant design.

A hot deck at the top of the core module stack houses a small buck regulator, which steps the 6-7 kV charging supply down to 900 VDC. This is passed to the next array of modules, which correct the pulse waveform in 900 V steps, ensuring that the 1% pulse flatness specifications are met. No synthesis is necessary for transients – only for droop remediation. We can merely stack the modules in an oil tank, as we do for conventional hard switch modulators at similar voltages (Figure 4).

Figure 5 and Figure 6 show the performance of the complete Marx modulator. Figure 5 shows the pulse using the core modules alone (the corrector modules are not charged). In this pulse, the voltage droop is based on the capacitance of the core modules. Figure 6 shows the impact of the core modules, which are switched into the circuit at 810 V increments throughout the pulse. This pulse has essentially no droop - only the 800 V sawtooth as each corrector is switched on sequentially.

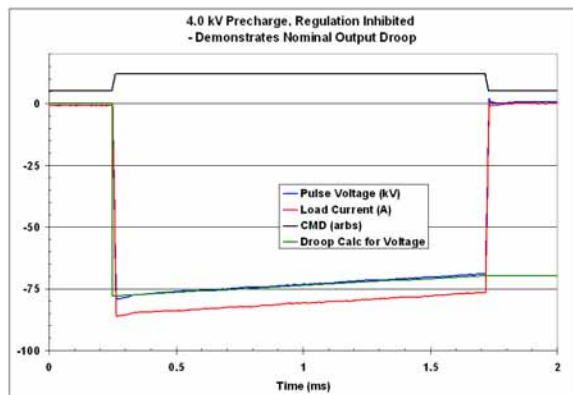

Figure 5. 20 Cores at 4.0 kV; correctors at 0 V; load = 900 Ω; regulation off; droops as per model.

This project is nearing completion. The corrector modules are completed and tested, and the core modules are in assembly and testing (Figure 2). Full specification pulses have been obtained with individual cells (Figure 5) and Figure 6, and assembly of the tank was initially completed in June 2008. Based on this testing, we have revised the module design for higher reliability, and are currently re-assembling the Marx system.

Delivery of the full specification system to a DOE laboratory will follow in late 2009, or as permitted within laboratory budget and schedule constraints.

ACKNOWLEDGEMENT

We gratefully acknowledge the U.S. Department of Energy, and our colleagues at Stanford Linear Accelerator Center, for SBIR funding and fruitful collaboration.

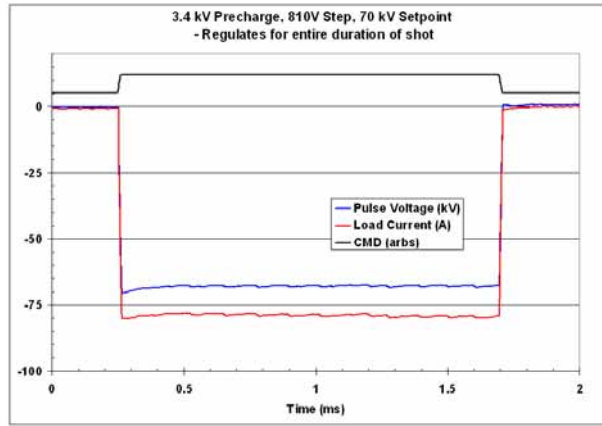

Figure 6. 20 Cores at 3.4 kV; correctors at 810 V; load = 900 Ω ; regulation 70 kV; regulates for full shot; regulation steps are larger.